

SXYxC 2 axes

- Clean type
- Cable duct

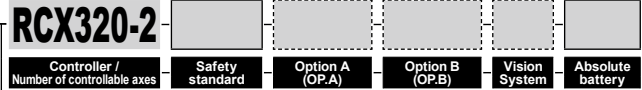

Ordering method

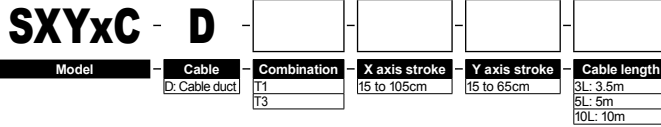

Specify various controller setting items. RCX320 ▶ **P.548**

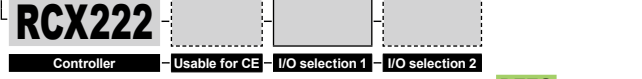

Specify various controller setting items. RCX222 ▶ **P.558**

Basic specifications

	X axis	Y axis
Axis construction <small>Note 1</small>	C14H	C14
AC servo motor output (W)	200	100
Repeatability <small>Note 2</small> (mm)	+/-0.01	+/-0.01
Drive system	Ball screw φ15	Ball screw φ15
Ball screw lead <small>Note 3</small> (Deceleration ratio) (mm)	20	20
Maximum speed <small>Note 4</small> (mm/sec)	1000	1000
Moving range (mm)	150 to 1050	150 to 650
Robot cable length (m)	Standard: 3.5 Option: 5, 10	
Degree of cleanliness	CLASS 10 <small>Note 5</small>	
Intake air (Nℓ/min)	60 <small>Note 6</small>	

Note 1. Use caution that the frame machining (installation holes, tap holes) differs from single-axis robots.
 Note 2. Positioning repeatability in one direction.
 Note 3. Leads not listed in the catalog are also available. Contact us for details.
 Note 4. When the X-axis stroke is longer than 850mm, resonance of the ball screw may occur depending on the operation conditions (critical speed). In this case, reduce the speed setting on the program by referring to the maximum speeds shown in the table below.
 Note 5. Per 1cf (0.1μm base), when suction blower is used.
 Note 6. The necessary intake amount varies depending on the use conditions and environment.

Maximum payload (kg)

Y stroke (mm)	XY 2 axes
150	20
250	17
350	15
450	13
550	11
650	9

Controller

Controller	Operation method
RCX320	Programming / I/O point trace / Remote command / Operation using RS-232C communication
RCX222	

SXYxC 2 axes T1

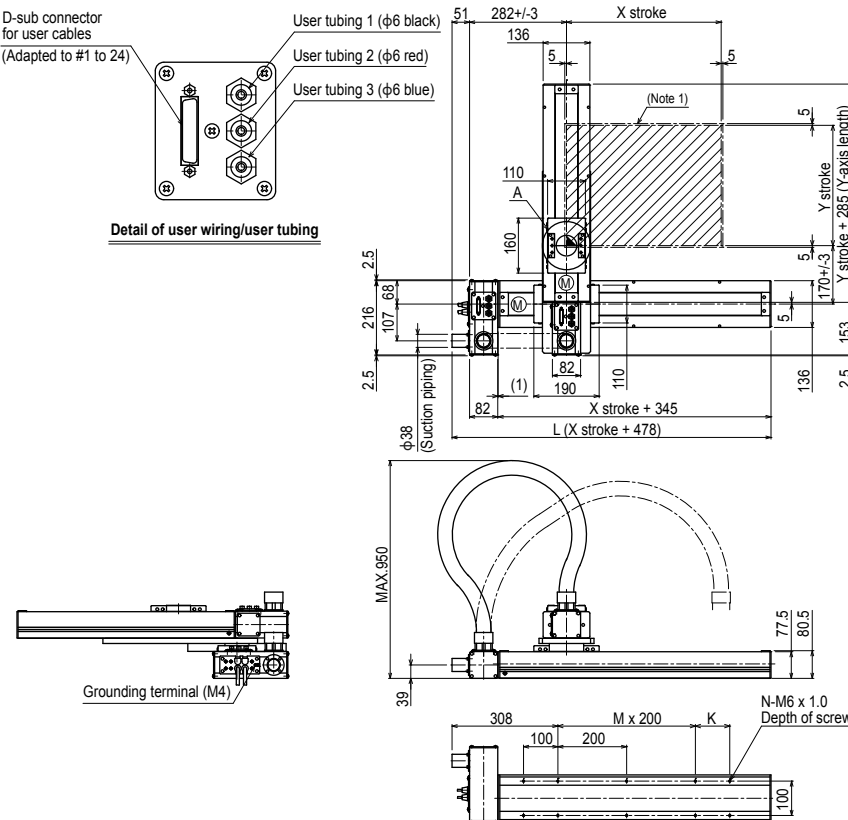

X stroke	150	250	350	450	550	650	750	850	950	1050	
	L	628	728	828	928	1028	1128	1228	1328	1428	1528
K	200	100	200	100	200	100	200	100	200	100	
M	0	1	1	2	2	3	3	4	4	5	
N	6	8	8	10	10	12	12	14	14	16	
Y stroke	150	250	350	450	550	650					
Maximum speed for each stroke (mm/sec) <small>Note 2</small>	1000						800	650	550		
Speed setting	-						80%	65%	55%		

Note 1. The moving range when returning to origin and the stop position when stopping by mechanical stopper.

Note 2. When the X-axis stroke is longer than 850mm, resonance of the ball screw may occur depending on the operation conditions (critical speed). In this case, reduce the speed setting on the program by referring to the maximum speeds shown in the table at the left.

SXYxC 2 axes T3

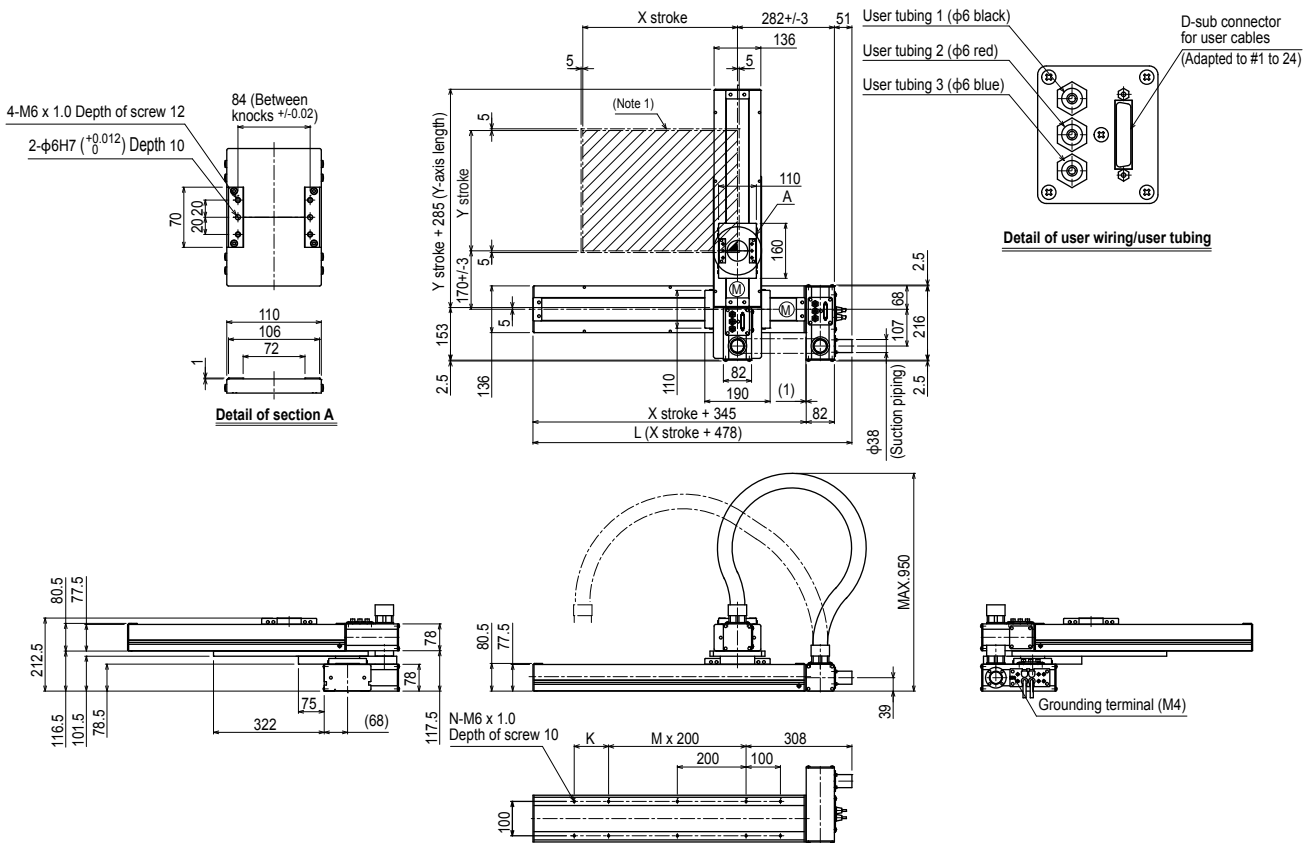

X stroke	150	250	350	450	550	650	750	850	950	1050
L	628	728	828	928	1028	1128	1228	1328	1428	1528
K	200	100	200	100	200	100	200	100	200	100
M	0	1	1	2	2	3	3	4	4	5
N	6	8	8	10	10	12	12	14	14	16
Y stroke	150	250	350	450	550	650				
Maximum speed for each stroke (mm/sec) ^{Note 2}					1000			800	650	550
Speed setting					-			80%	65%	55%

Note 1. The moving range when returning to origin and the stop position when stopping by mechanical stopper.

Note 2. When the X-axis stroke is longer than 850mm, resonance of the ball screw may occur depending on the operation conditions (critical speed). In this case, reduce the speed setting on the program by referring to the maximum speeds shown in the table at the left.