

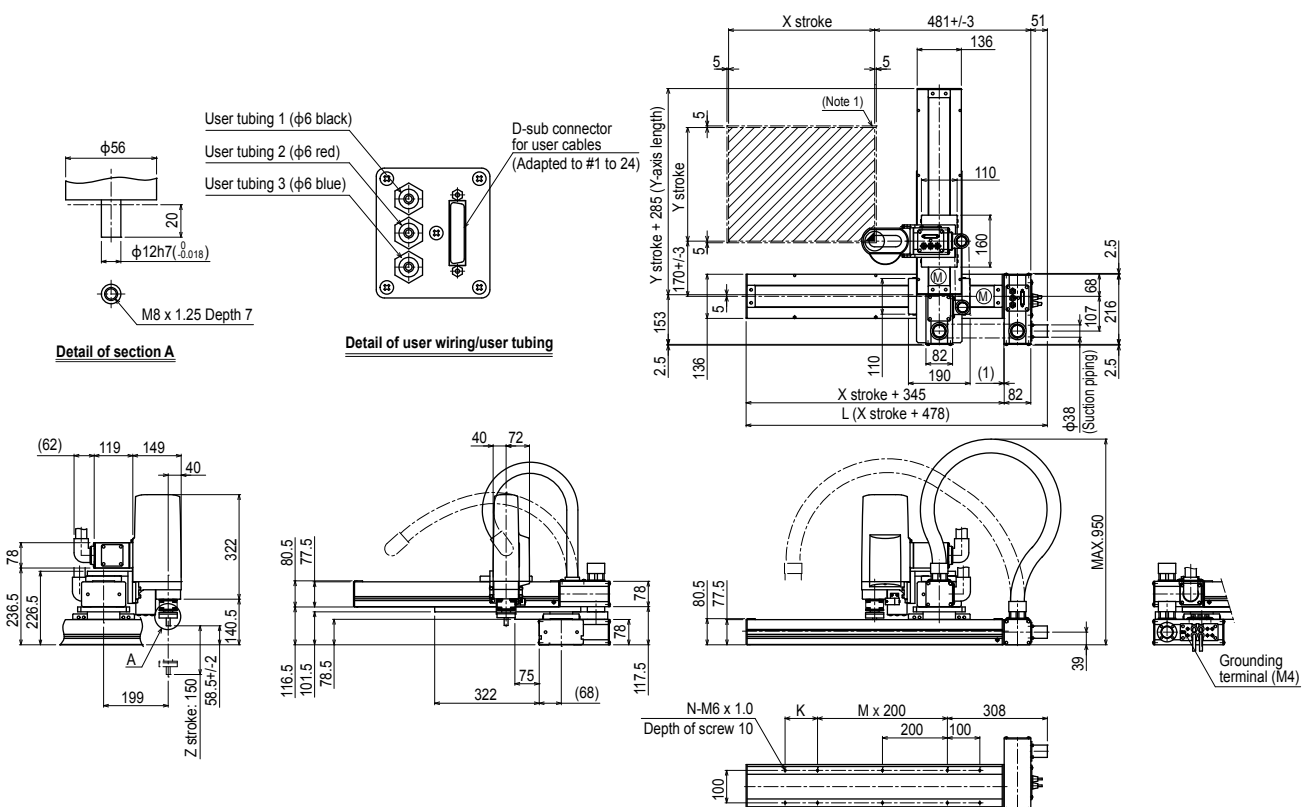

SXYxC 4 axes / ZRSC T3



X stroke	150	250	350	450	550	650	750	850	950	1050	
L	628	728	828	928	1028	1128	1228	1328	1428	1528	
K	200	100	200	100	200	100	200	100	200	100	
M	0	1	1	2	2	3	3	4	4	5	
N	6	8	8	10	10	12	12	14	14	16	
Y stroke	150	250	350	450	550	650					
Z stroke	150										
Maximum speed for each stroke (mm/sec) Note 2	X axis		1000				800	650	550		
	Speed setting		-				80%	65%	55%		

Note 1. The moving range when returning to origin and the stop position when stopping by mechanical stopper.

Note 2. When the X-axis stroke is longer than 850mm, resonance of the ball screw may occur depending on the operation conditions (critical speed). In this case, reduce the speed setting on the program by referring to the maximum speeds shown in the table at the left.