

YP220BXR 3 axes



Ordering method

YP220BXR **RCX340-3**

Model	Cable length	Controller / Number of controllable axes	Safety standard	Option A (OP.A)	Option B (OP.B)	Option C (OP.C)	Option D (OP.D)	Option E (OP.E)	Absolute battery
	3L: 3.5m 5L: 5m 10L: 10m								

Specify various controller setting items. RCX340 ▶ **P.566**

Specifications

	X axis	Z axis	R axis
AC servo motor output (W)	200	200	60
Repeatability ^{Note 1} (mm)	+/-0.05	+/-0.05	+/-0.1
Drive system	Timing belt	Timing belt	Ball Reducer
Deceleration ratio (mm)	Equivalent to lead 24	Equivalent to lead 20	1/18
Maximum speed ^{Note 2} (XZ: mm/sec) (R: °/sec)	1440	1200	1000
Moving range (XZ: mm) (R: °)	200	100	+/-180
Cycle time (sec)	0.62 ^{Note 3}		
Maximum payload (kg)	1		
R-axis allowable moment inertia (kgm ² [kgfcm ²])	0.00098 [0.01]		
Robot cable length (m)	Standard: 3.5 Option: 5, 10		
Weight (kg)	19		

Note 1. Positioning repeatability precision in a single swing when residual vibration is stabilized (variable depending on the load and stroke).
 Note 2. When the moving stroke is short, the maximum speed may not be reached.
 Note 3. Reciprocating time in vertical direction (50mm) and longitudinal direction (150mm) with the arch amount of 50 (when executing rough-positioning arch motion with 1kg load).

Controller

Controller	Power consumption (VA)	Operating method
RCX340	700	Programming / I/O point trace / Remote command / Operation using RS-232C communication

YP220BXR

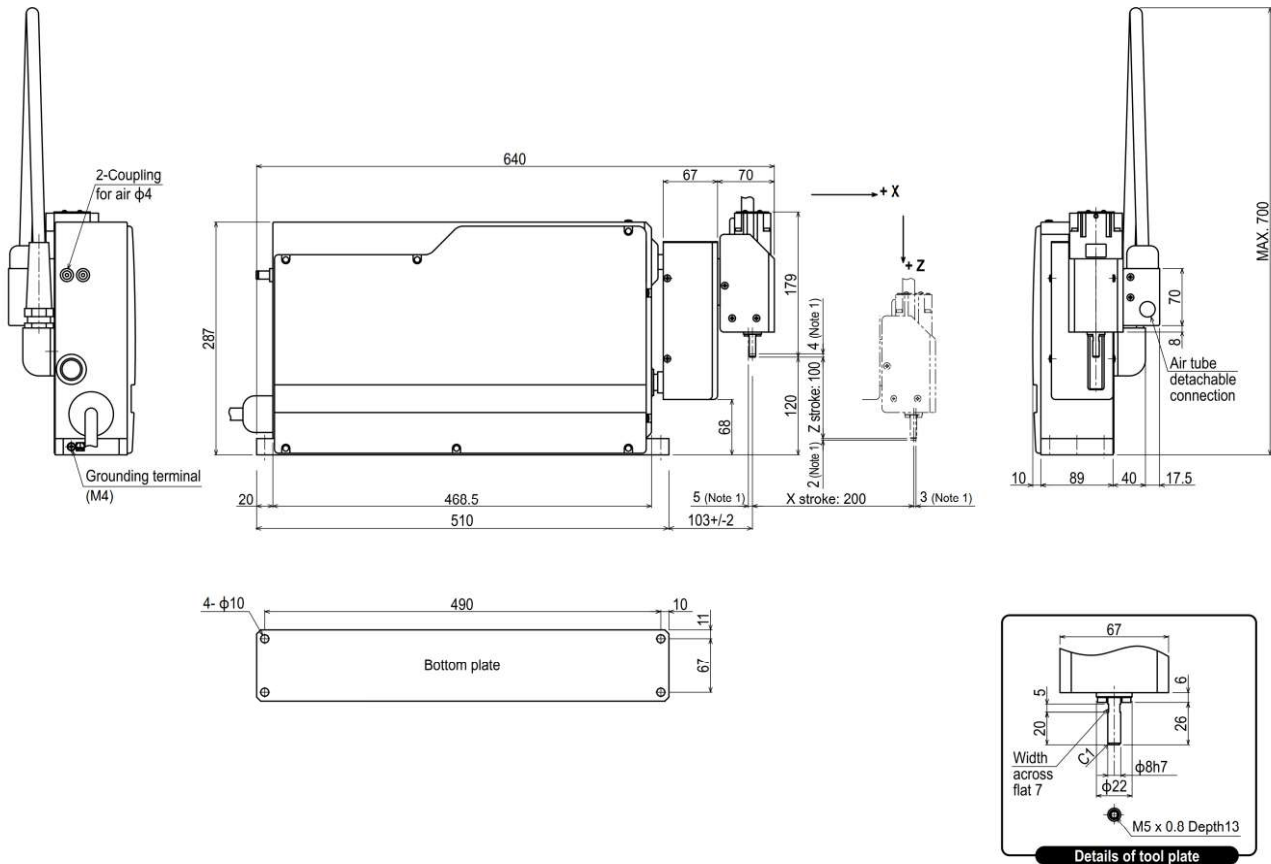

Note 1. Distance to mechanical stopper.
 Note 2. Return-to-origin on the YP220BXR is by absolute reset. So the origin position must be set the first time (making initial settings) but after that is not required.

Articulated robots
YA

Linear conveyor/modules
LCM100

Motor-less single axis actuator
Robonity

Compact single-axis robots
TRANSENO

Single-axis robots
FLIP-X

Linear motor single-axis robots
PHASER

Cartesian robots
XY-X

SCARA robots
YK-X

Pick & place robots
YP-X

CLEAN

CONTROLLER INFORMATION

2-axes

3-axes

4-axes