

Double cam type

YRG-2005W/2810W/4220W



Basic specifications

Model name	YRG-2005W	YRG-2810W	YRG-4220W	
Model number	KCF-M2012-A0	KCF-M2012-B0	KCF-M2012-C0	
Holding power	Max. continuous rating (N)	50	150	250
	Min. setting (% (N))	30 (15)	30 (45)	30 (75)
	Resolution (% (N))	1 (0.5)	1 (1.5)	1 (2.5)
Open/close stroke (mm)		5	10	19.3
	Max. rating (mm/sec)	60	60	45
Speed	Min. setting (% (mm/sec))	20 (12)	20 (12)	20 (9)
	Resolution (% (mm/sec))	1 (0.6)	1 (0.7)	1 (0.45)
	Holding speed (Max.) (%)	50		
Repetitive positioning accuracy (mm)	+/-0.03			
Guide mechanism	Linear guide			
Max. holding weight ^{Note 1} (kg)	0.5	1.5	2.5	
Weight (g)	200	350	800	

- Holding power control : 30 to 100% (1% steps) • Speed control : to 100% (1% steps)
- Acceleration control : to 100% (1% steps) • Multipoint position control : 10,000 max.

Note. Design the finger as short and lightweight as possible.

Note. Set the parameters and holding power (%) of the holding movement command so that any excessive shock is not applied to the finger during operation.

Note. When installing or uninstalling the finger, tighten the bolts while the finger is being held securely so that any excessive force or shock is not applied to the guide block.

Note. Workpiece weight that is able to be held may greatly vary depending on the material, shape, and/or holding surface conditions of the finger.

Note 1. Design the weight of a workpiece to be held so that it is approximately 1/10 to 1/20 of the holding power. (Consider further allowance when moving and swinging the gripper that keeps holding a workpiece.)

Gripping power vs. gripping power setting (%)

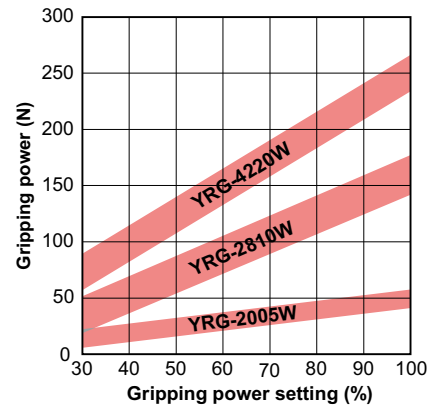

- Graph shows a general guide to gripping power versus gripping power setting (%). Variations will appear in the actual gripping power.

Allowable load and load moment

				YRG-2005W	YRG-2810W	YRG-4220W
Guide	Allowable load	F	N	1000	1000	2000
	Allowable pitching moment	Mp	N·m	6.7	8.1	20.1
	Allowable yawing moment	My	N·m	4	4.8	12
	Allowable rolling moment	Mr	N·m	5.1	7.8	25.9
Finger	Max. weight (1 pair)		g	40	80	200
	Max. holding position	L	mm	30	30	50
	Max. overhang	H	mm	20	20	30

- Mount the finger so that the allowable load and load moment of the guide do not exceed the values stated in the table above.
- Make the adjustment so that the finger weight, holding length (L) from the installation surface to the holding point, and overhang (H) do not exceed the values stated in the table above.
- Please contact your YAMAHA sales dealer for further information on combination of L and H.

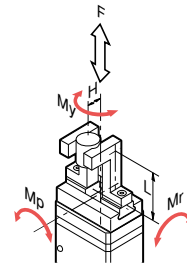

YRG-2005W/2810W/4220W

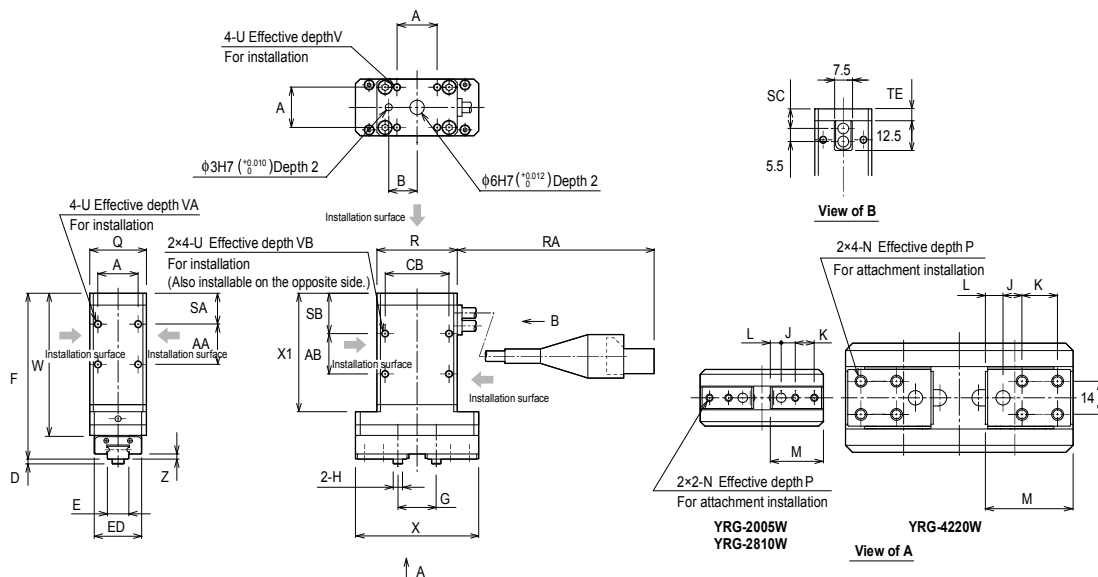

	A	AA	AB	B	CB	D	E	ED	F	G	H	J	K	L
YRG-2005W	17	17	17	12	27	2	9 ⁰ / _{-0.05}	20	74	10.6 to 15.6	φ4 ⁰ / _{-0.012}	6	8	4.6
YRG-2810W	24	24	14	15	38	2	1 ⁰ / _{-0.05}	25	80	12.6 to 22.6	φ5 ⁰ / _{-0.012}	7	10	5.65
YRG-4220W	36	25	13	20	50	3	2 ⁰ / _{-0.05}	40	90	17.0 to 36.3	φ6 ⁰ / _{-0.012}	8	15	

	M	N	P	Q	R	RA	SA	SB	SC	TE	U	V	VA	VB	W	X	X1	Z
YRG-2005W	22.5	M3	5	24	34	165+/-10	13	17	8.3	5	M3	5	6	6	64	52	54	2.2
YRG-2810W	27.5	M4	5	32	46	140+/-10	16	21	9.3	6	M4	6	8	8	71	67	61	2
YRG-4220W	37	M5	8	46	60	235+/-10	18	24	10.8	7.5	M5	7.5	8	10	76	96	6	

Articulated robots
YA
Linear conveyor moduli
LCM100
Motor-less single axis actuator
Robonity
Compact single-axis robots
TRANSERVO
Single-axis robots
FLIP-X
Linear motor single-axis robots
PHASER
Cartesian robots
XY-X
SCARA robots
YK-X
Pick & place robots
YP-X
CLEAN
CONTROLLER INFORMATION
Robot positioner
Pulse string driver
Robot controller
Electric gripper
Option