

SRD04

Rod type (With support guide)



- CE compliance
- Origin on the non-motor side is selectable: Lead 6, 12

Ordering method

SRD04

Model	Lead	Model	Brake	Origin position	Bracket plate	Stroke	Cable length
	12: 12mm 06: 6mm 02: 2mm	S: Straight model J: Space-saving model (motor installed on top)	N: With no brake B: With brake	N: Standard Z: Non-motor side	N: No plate H: With plate	50 to 300 (60mm pitch)	Note 4 1K: 1m 3K: 3m 5K: 5m 10K: 10m

S2

Robot positioner	I/O
S2: TS-S2	NP: NPN PN: PNP CC: CC-Link DN: DeviceNet™ EP: EtherNet/IP™ PT: PROFINET GW: No I/O board

SH

Robot positioner	I/O	Battery
SH: TS-SH	NP: NPN PN: PNP CC: CC-Link DN: DeviceNet™ EP: EtherNet/IP™ PT: PROFINET GW: No I/O board	B: With battery (Absolute) N: None (Incremental)

SD

Robot driver	I/O cable
SD: TS-SD	f: 1m

Note 1. See P.153 for grease gun nozzles.
 Note 2. When "2mm lead" is selected, the origin position cannot be changed (to non-motor side).
 Note 3. If changing from the origin position at the time of purchase, the machine reference amount must be reset. For details, refer to the manual.

Note 4. The robot cable is flexible and resists bending.
 Note 5. See P.522 for DIN rail mounting bracket.
 Note 6. Select this selection when using the gateway function. For details, see P.66.

Basic specifications

Motor	42 □ Step motor	
Resolution (Pulse/rotation)	20480	
Repeatability (mm)	+/-0.02	
Deceleration mechanism	Ball screw φ8	Ball screw φ10
Ball screw lead (mm)	12	6
Maximum speed (mm/sec)	500	250
Maximum payload (kg)	Horizontal: 25	Vertical: 4
Max. pressing force (N)	150	300
Stroke (mm)	50 to 300 (50pitch)	
Lost motion	0.1mm or less	
Rotating backlash (°)	+/-0.05	
Overall length (mm)	Horizontal	Vertical
	Stroke+263	Stroke+303
Maximum outside dimension of body cross-section (mm)	W48 × H58	
Cable length (m)	Standard: 1 / Option: 3, 5, 10	

Note 1. The maximum speed needs to be changed in accordance with the payload.
 See the "Speed vs. payload" graph shown on the right. For details, see P. 152.
 Additionally, when the stroke is long, the maximum speed is decreased due to the critical speed of the ball screw.
 See the maximum speed table shown at the lower portion of the drawing.

Speed vs. payload

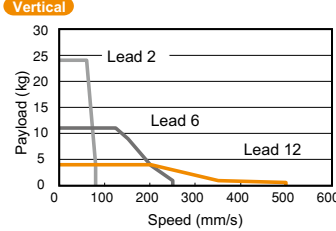
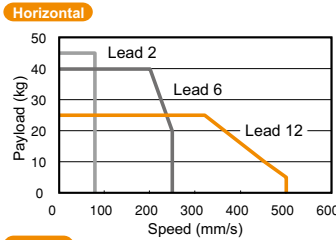

Running life

5000 km on models other than shown below.
 Running life of only the model shown below becomes shorter than 5000 km depending on the payload, so check the running life curve.

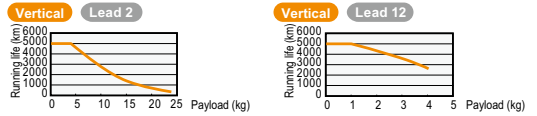

Note. See P.153 for running life distance to life time conversion example.

Controller

Controller	Operation method	Controller	Operation method
TS-S2	I/O point trace / Remote command	TS-SD	Pulse train control
TS-SH			

SRD04 Straight model S

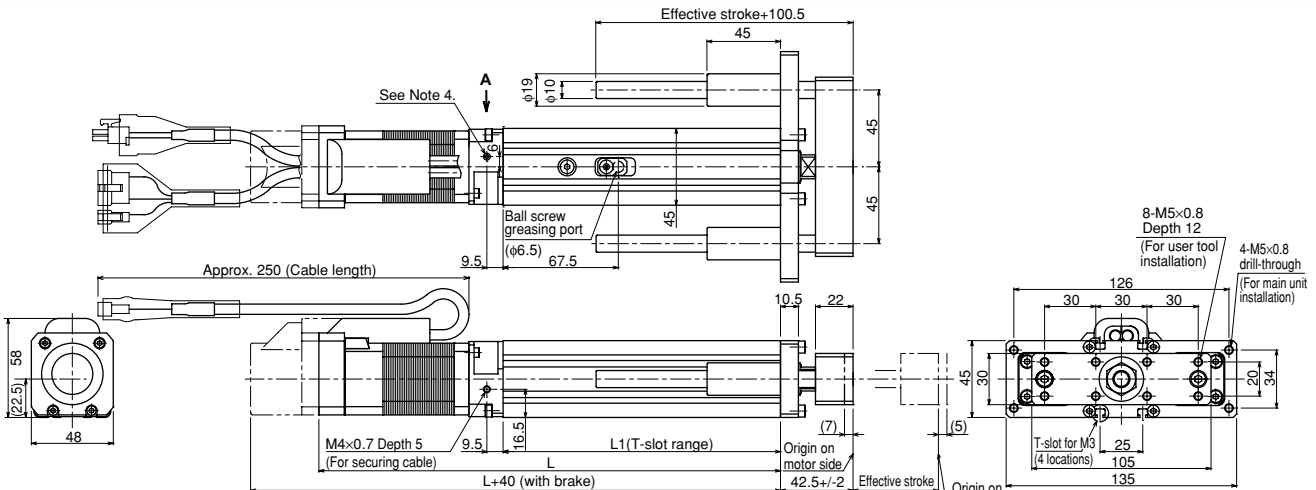

Option: Horizontal installation plate (foot)

* Contents of option: Plate, 2 pcs., Nut, 12 pcs.
 See our robot manuals for additional settings.

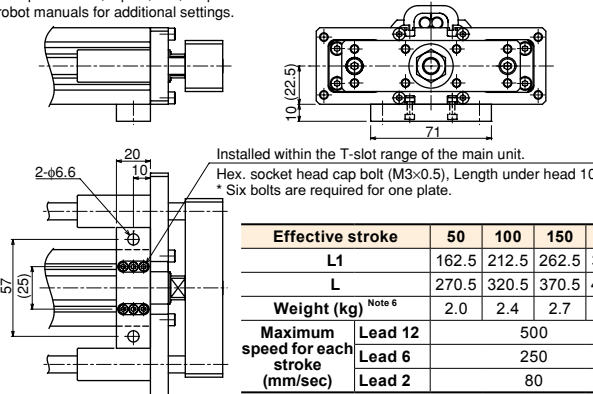

Effective stroke	50	100	150	200	250	300
L1	162.5	212.5	262.5	312.5	362.5	412.5
L	270.5	320.5	370.5	420.5	470.5	520.5
Weight (kg)	2.0	2.4	2.7	3.0	3.3	3.7
Maximum speed for each stroke (mm/sec)	Lead 12	500		440	320	
	Lead 6	250		220	160	
	Lead 2	80		72	53	

Note 1. It is possible to apply only the axial load.
 Use the external guide together so that any radial load is not applied to the rod.
 Note 2. For lead 2mm specifications, the origin on the non-motor side cannot be set.
 Note 3. When running the cables, secure cables so that any load is not applied to them.
 Note 4. Remove the M4 hex. socket head cap set bolts and use them to secure the cables. (Effective screw thread depth 5)
 Note 5. The cable's minimum bend radius is R30.
 Note 6. Models with a brake will be 0.2kg heavier.
 Note 7. Distance to mechanical stopper.

SRD04 Space-saving model (motor installed on top) U

Option: Horizontal installation plate (foot)

* Contents of option: Plate, 2 pcs., Nut, 12 pcs.
See our robot manuals for additional settings.

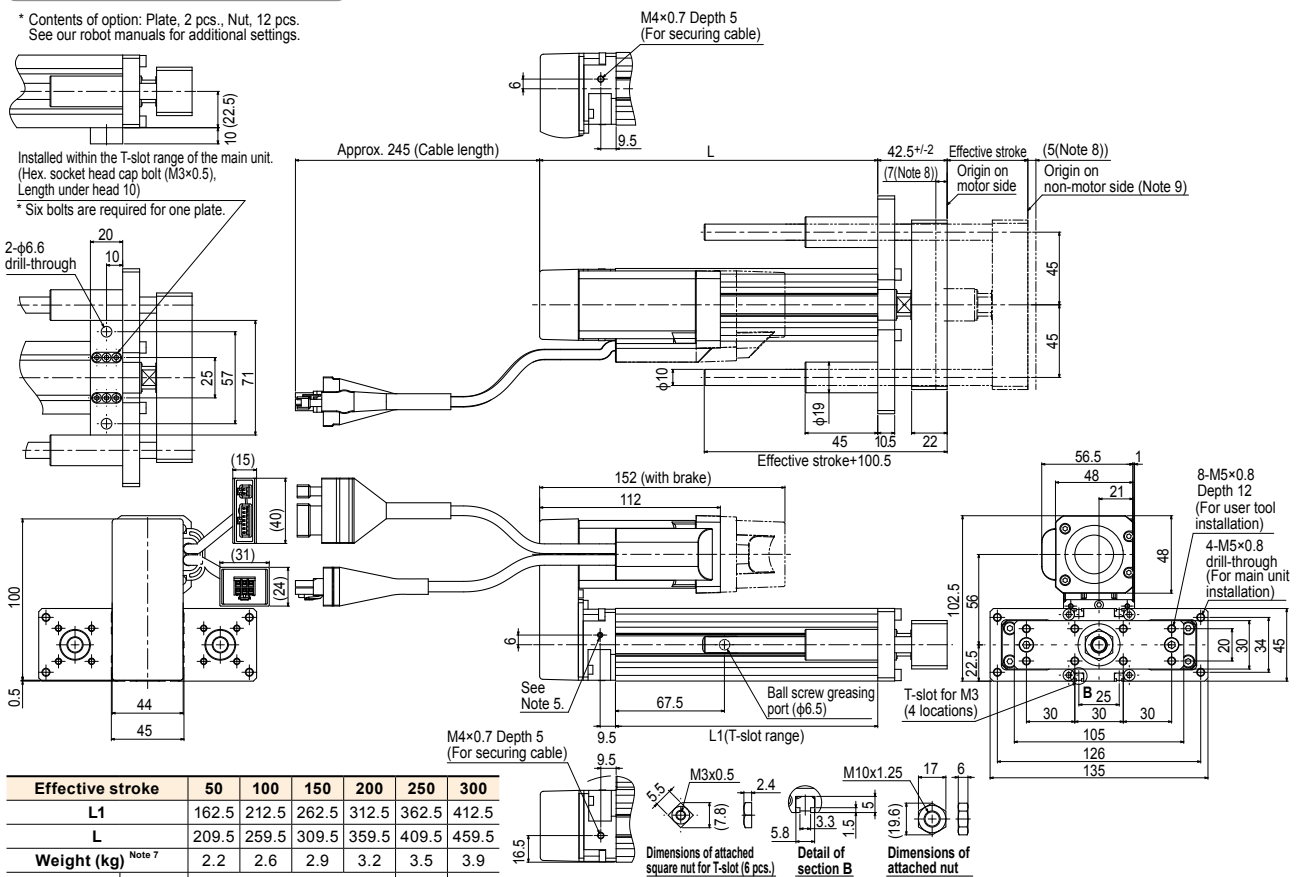

Effective stroke	50	100	150	200	250	300
L1	162.5	212.5	262.5	312.5	362.5	412.5
L	209.5	259.5	309.5	359.5	409.5	459.5
Weight (kg) ^{Note 7}	2.2	2.6	2.9	3.2	3.5	3.9
Maximum speed for each stroke (mm/sec)	Lead 12	500		440	320	
	Lead 6	250		220	160	
	Lead 2	80		72	53	

Note 1. It is possible to apply only the axial load.
Use the external guide together so that any radial load is not applied to the rod.
Note 2. The orientation of the width across flat part is undefined to the base surface.

Note 3. Use the support guide together to maintain the straightness.
Note 4. When running the cables, secure cables so that any load is not applied to them.
Note 5. Remove the M4 hex. socket head cap set bolts and use them to secure the cables. (Effective screw thread depth 5)
Note 6. The cable's minimum bend radius is R30.
Note 7. Models with a brake will be 0.2kg heavier.
Note 8. Distance to mechanical stopper.
Note 9. For lead 2mm specifications, the origin on the non-motor side cannot be set.